

6- CHAPA APOIO ROLETE ESP. 1/2"
(2 PEÇAS POR SUPORTE)
ESC. 1:10

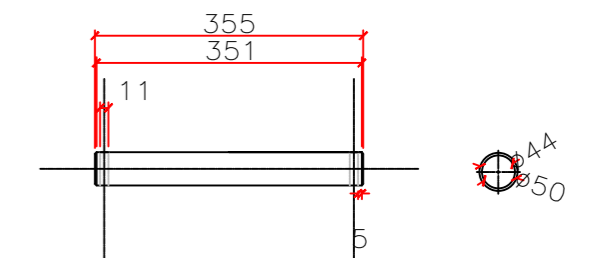

7 - ANEL DO ROLETE (2 PEÇAS POR SUPORTE)
ESC. 1:10



8- EIXO DO ROLETE PARA TUBO Ø400MM (1 PEÇA POR SUPORTE)
ESC. 1:10

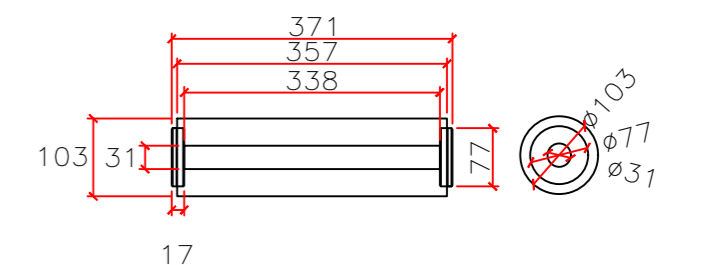

9- ROLETE PARA TUBO Ø400MM (1 PEÇA POR SUPORTE)
ESC. 1:10

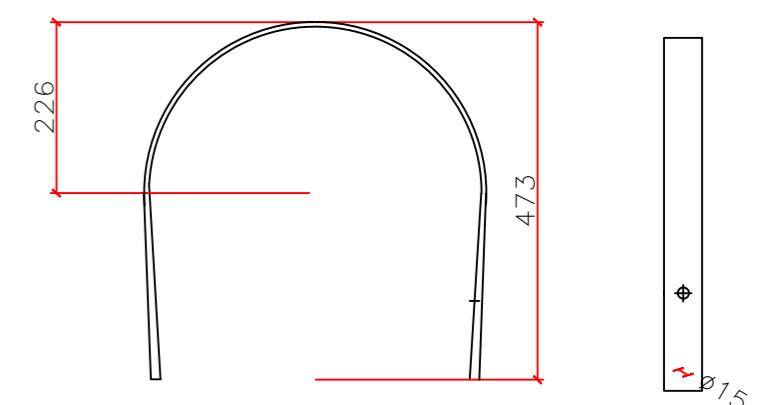

10- CHAPA ABRAÇADEIRA 1/4" PARA TUBO Ø400MM
(1 PEÇA POR SUPORTE)
ESC. 1:10

1- BASE SUPERIOR DO SUPORTE ESP. 1/2"
(2 PEÇAS POR SUPORTE)
ESC. 1:10

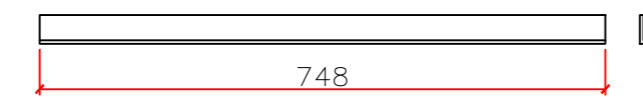

2- HASTE LATERAL - CANTONEIRA 1/4"x1.1/2"
(4 PEÇAS POR SUPORTE)
ESC. 1:10



3- PORCA SEXTAVADA 1/2" UNC 13 FIOS
ZINCADO BRANCO E ARRUELA LISA 1/2" ZINCADO
BRANCO (4 PEÇAS POR SUPORTE)
ESC. 1:10

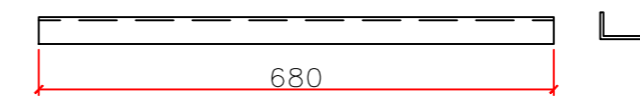

4- PERFIL U 3"x1.1/2" (2 PEÇAS POR SUPORTE)
ESC. 1:10

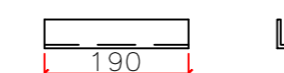

5- HASTE FRONTAL INFERIOR, CANTONEIRA
1/4"x1.1/2"
(2 PEÇAS POR SUPORTE)
ESC. 1:10

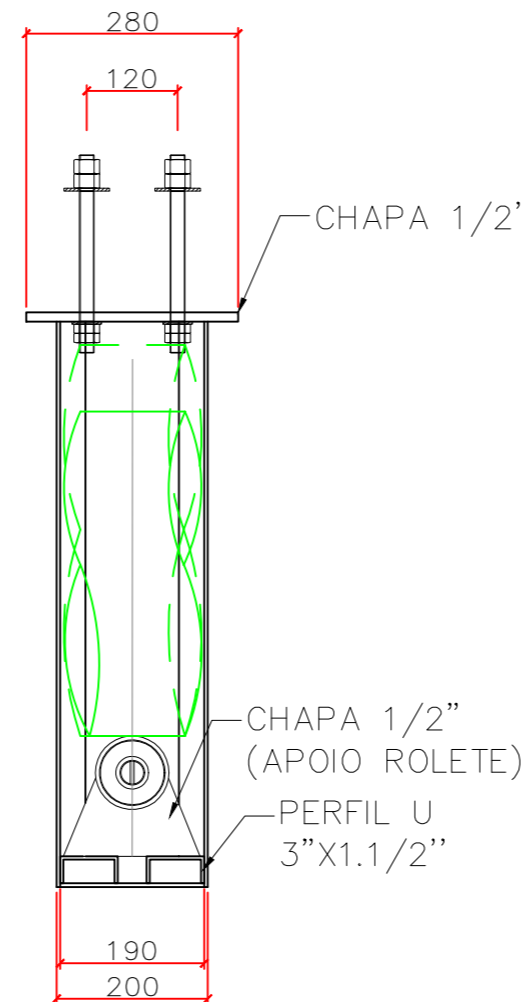
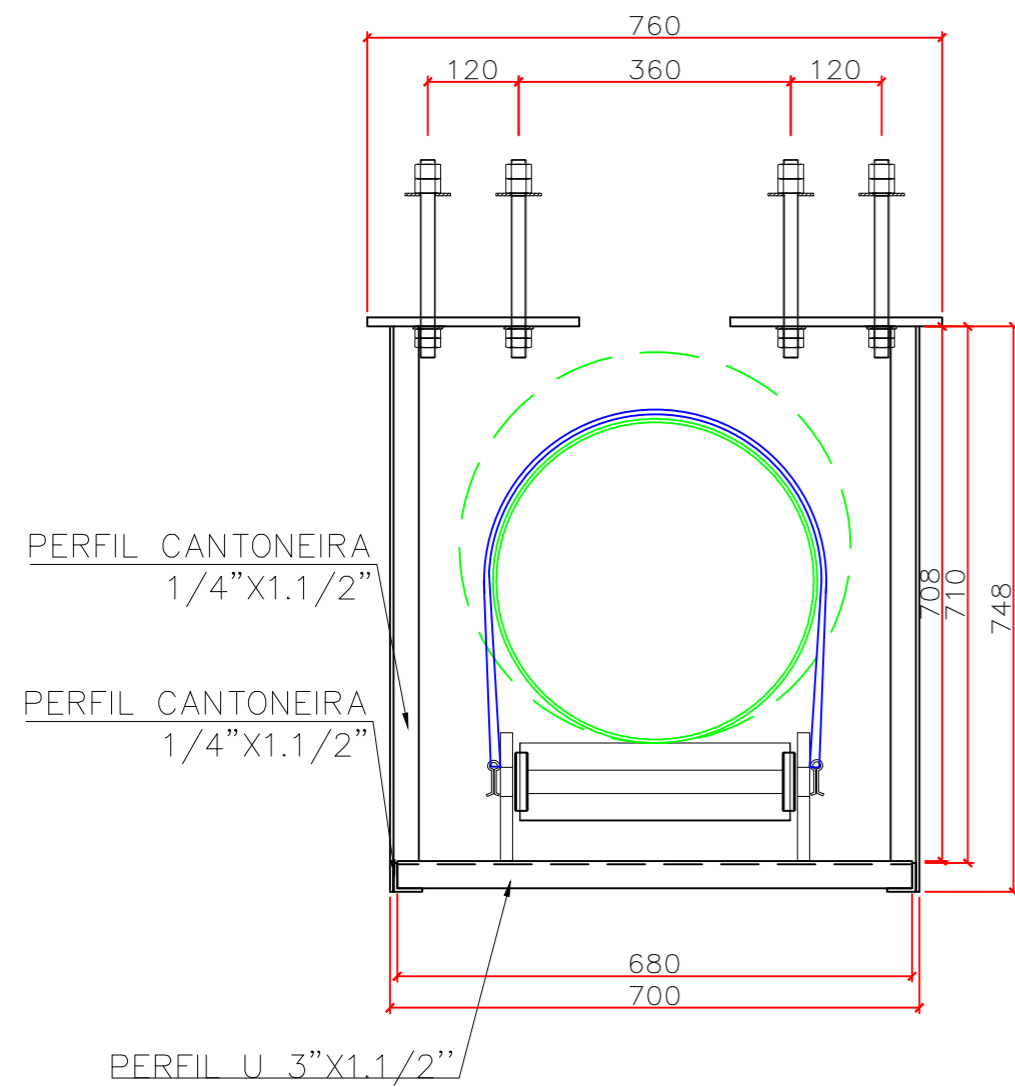

SUPORTE PARA TUBULAÇÃO DE FERRO FUNDIDO
ESC. 1:10



BOLSA TUBO PARA ÁGUA Ø400MM

TUBO PARA ÁGUA Ø400MM

PERFIL CANTONEIRA
1/4"x1.1/2"

CHAPA ABRAÇADEIRA 1/4"
PARA TUBO Ø400MM

PERFIL CANTONEIRA
1/4"x1.1/2"

PERFIL U 3"x1.1/2"

SUPORTE POSICIONADO NA PONTE
ESC. 1:10

SAMAE JARAGUÁ DO SUL		SERVIÇO AUTÔNOMO MUNICIPAL DE ÁGUA E ESGOTO	
PADRÃO:	SUPORTE PARA TUBULAÇÃO Ø400MM	PRANCHA:	02/03
REVISÃO:		REVISÃO:	00
DESCRIÇÃO:	PLANTA BAIXA, CORTE E DETALHES	ESCALA:	INDICADA
RESPONSÁVEL TÉCNICO:	ENGº BRUNO DILMO DE SOUZA	DATA:	OUT/23
		DESENHO:	NICOLAS LEMES